

Operating Instructions

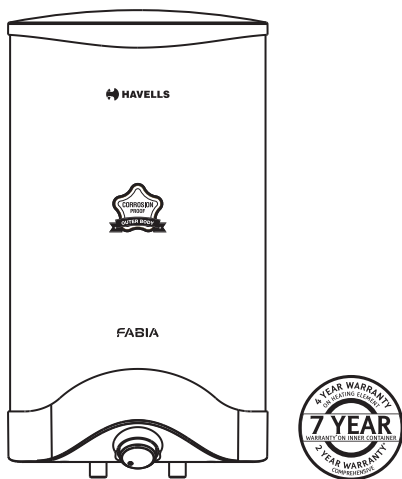

Storage Electric Water Heater
Fabia 6 L, 10 L, 15 L & 25 L



HAVELLS

Dear Customer,

We congratulate you on choosing a **HAVELLS** Electric Water Heater, one of the highly prestigious brand in India. Meticulously designed, using only the highest quality materials and components, your electric water heater is designed to have many years of trouble free operation.

To enable your electric water heater to give you many years of perfect trouble free service, we recommend you to follow the advice contained in this Instruction manual very carefully.

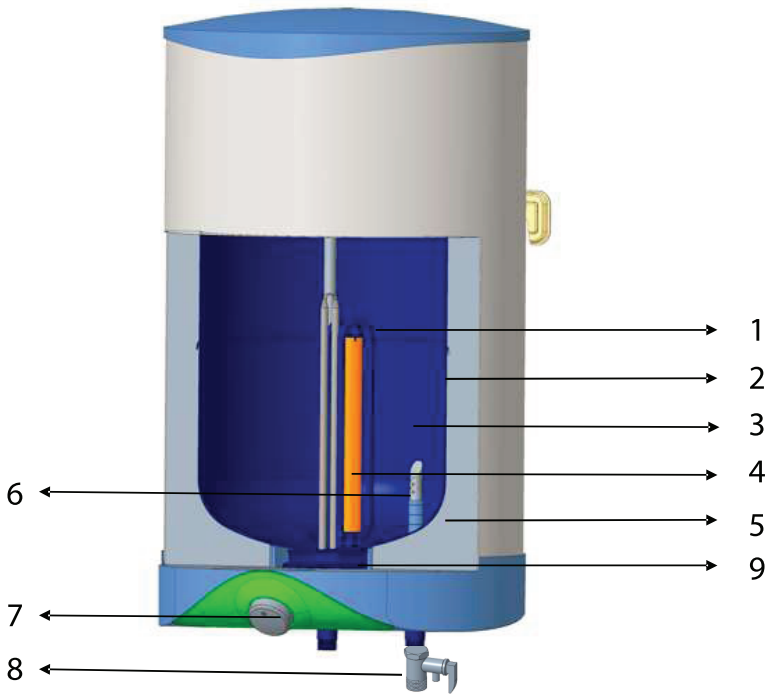

1. High quality incoloy 800 glass coated heating element
2. Heavy guage inner tank
3. Fero glass coating layer
4. Heavy-Duty anode rod
5. Energy saving high density PUF insulation
6. Water tubes with whirlflow
7. Thermostat with adjustable temperature knob
8. Multifunctional safety valve
9. 4 Bolt flange

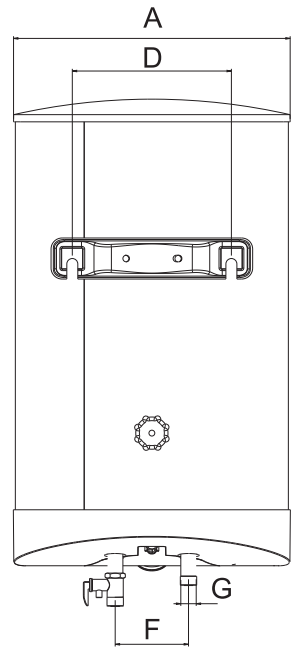
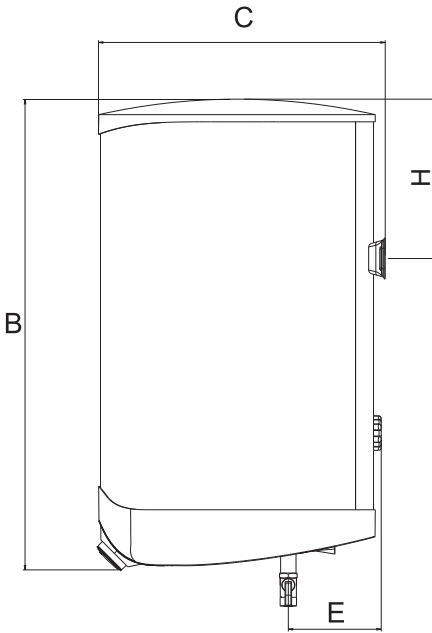

Model	A	B	C	D	E	F	G	H
Fabia 06 L	259 mm	412 mm	272 mm	163 mm	94 mm	100 mm	21 mm	134 mm
Fabia 10 L	327 mm	447 mm	341 mm	163 mm	101 mm	100 mm	21 mm	158 mm
Fabia 15 L	327 mm	545 mm	341 mm	163 mm	101 mm	100 mm	21 mm	148 mm
Fabia 25 L	377 mm	595 mm	391 mm	163 mm	127 mm	100 mm	21 mm	153 mm

*Note: All dimensions are in mm, dimensions tolerance ± 5 mm
 Dimensions in mm above refer to mechanical figures in this page.

Technical Specifications:

S. No.	Parameter	Fabia	Fabia	Fabia	Fabia
1.	Rated Capacity in L	6 L	10 L	15 L	25 L
2.	Mounting	Vertical	Vertical	Vertical	Vertical
3.	Rated Voltage in Volt & frequency in Hz	230 V, 1 Phase, 50 Hz, AC	230 V, 1 Phase, 50 Hz, AC	230 V, 1 Phase, 50 Hz, AC	230 V, 1 Phase, 50 Hz, AC
4.	Rated Power Input in W	3000 W	2000 W	2000 W	2000 W
5.	Rated Input Current in Ampere	13.04 A	8.7 A	8.7 A	8.7 A
6.	Max. Hot Water Output Temp. (°C)	75 °C	75 °C	75 °C	75 °C
7.	Rated Pressue in MPa	0.8 MPa	0.8 MPa	0.8 MPa	0.8 MPa
8.	Standing Loss in kWh / 24 h / 45 °C	0.265 kWh	0.332 kWh	0.381 kWh	0.465 kWh
9.	Reheating Time in Minutes to raise 50 °C	6 min	15 min	20 min	35 min
10.	Mixing Factor Maximum (%)	30%	30%	30%	30%
11.	Weight of water heater in kg				
	- Empty	5.7 kg	8.6 kg	10.1 kg	12.8 kg
	- Water Filled	12 kg	18.9 kg	25.6 kg	38.1 kg
12.	Water Proof Degree	IP X 4	IP X 4	IP X 4	IP X 4
13.	Class of Appliance	Class I	Class I	Class I	Class I

WARNING:

The installer should review the contents of this manual along with the owner after completion of installation and the manual should be left with the owner and placed at a place close to the installation.

Key Features:



FeroGlass

1. FeroGlass Coated Tank with single Weld Line Design:
 - A. Made of Ultra thick superior quality steel.
 - B. Provides more corrosion resistance and anti-rust property compared to standard inner tank designs resulting longer life
 - C. Single weld line on the inner tank eliminates the risk of water leakage



**Heavy Duty
anode**

2. Heavy Duty Anode Rod Protects Tank From Corrosion:

With steel core, Heavy Duty anode rod protects enamelled tank from rust and corrosion.



**Incoloy
Element**

3. Incoloy Heating Element:

Incoloy 800 Coated Heating Element offers superior heating performance with its excellent resistance to both oxidation & carbonization at high temp. setting. Also resists erosion against most extreme and hard water conditions thus extending life span of heating element with minimum energy loss.



**Polyurethane
Insulation**

4. Energy Saving High Density Puf Insulation :

CFC free thicker PUF insulation offers complete protection against radiant heat loss.



**Whirl flow
Technology**

5. Water Tubes with Whirl Flow :

The whirl flow ensures no immediate direct contact between cold and hot water for a faster heating and maximum energy saving effect.



**Thermal
Cut out**

6. Thermal Cut Out :

Cuts off electric power to guarantee safety , in case the water temp. exceeds the highest temp. Beyond Pre-set of the thermostat.



**Multi functional
Valve**

7. Multifunctional Safety Valve (MFV) :

The MFV used with this unit is a unique safety valve. This has four functions

 1. Pressure Release Valve (PRV)
 2. Non return Valve (NRV)
 3. Vacuum Release Valve (VRV)
 4. Drain Device



**Temperature
Control Knob**

8. Adjustable Temp. Knob with Thermostat :
Allows a manual setting for heating of water between ambient temperature to 75 °C



**4 Bolt
Flange**

9. **4 Bolt Flange**
Provides an easier way for product maintenance.

Safety Devices:

Havells Water Heater is built-in with a host of Safety Devices to ensure your safety at all times. The operation of these device are described below:

A. Thermostat

Capillary type thermostat: This device “cut-off” and “cut-in” the power supply between a narrow band of temperature range. The indicator lamp provided with this circuit glow and un-glow during cut-in and cut-off. This shows the proper working of the thermostat. This device is provided with an adjustable knob to set the desired water temperature.

B. Thermal Cutout

A non-self resetting thermal cutout is provided as a safety device. When the thermostat fails to function, this cut-off the power at $95^{\circ}\text{C} \pm 5^{\circ}\text{C}$

The thermal cutout has to be manually reset before the heater can start operating again.

C. Multi Function Valve (MFV)

1. This valve prevents the built-up of excessive pressure within the water heater by releasing water from the drain.
2. It also acts as a non-return valve to avoid the return of water from the water heater back to supply, thereby prevent the dry heating.
3. It acts as an expansion valve to allow the hot water expansion during heating which flows back through drain.
4. Customer can ensure proper working of the MFV by cleaning of salt deposits, by lifting the drain lever up. Customer can drain out the water from tank in case of prolonged non-use of water heater.

Installation & Safety:

- A. Always use services of qualified plumber/electrician to install this unit.
- B. For easy installation and servicing, enough space should be provided around this unit (5 cm from ceiling, 50 cm from sides & minimum 1.8 m from ground).
- C. Ensure following tools and accessories are made available before installation of this unit (not provided by company).
 1. Drilling machine with concrete drill bit sets, spanner and tool kit.
 2. PVC pipe for drain

Preparation of Wall Structure

For installation of this unit, you need to prepare the wall suitably.

A. In case of hollow brick walls.

1. Dig up sufficient space to accommodate the wall mounting bracket (bracket supplied with water heater) of minimum depth 10 cm
2. Fill up the complete dig up space with cement concrete.
3. Ensure cement concrete is properly cured/set.
4. Then, the wall bracket can be fixed with the help of bolts provided along with the unit.

B. In case of solid walls

Follow process as below :

1. Drill hole in wall as shown Picture 1.
2. Insert the nut/bolt assembly in drilled hole, take out the bolt (as shown) Picture 1.
3. Fix the wall plate with the bolt and washer by testing testing till the wall plate is firmly fixed, in order to carry the weight of water heater safely (with water).

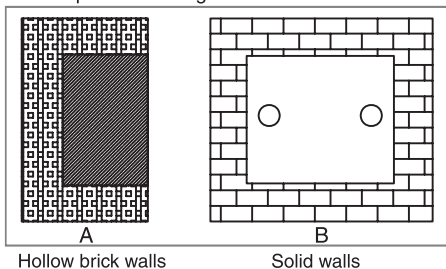

Mounting

Now, the water heater can be hooked on the wall bracket.

1. After hooking on bracket, tug downward the water heater and ensure both fingers of bracket are properly seated in the mounting slot.

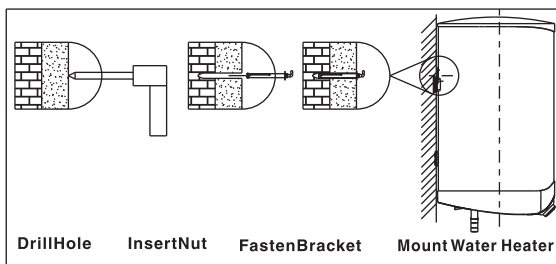

Picture 1

2. Do not install in the area of direct sunlight and water splashes.

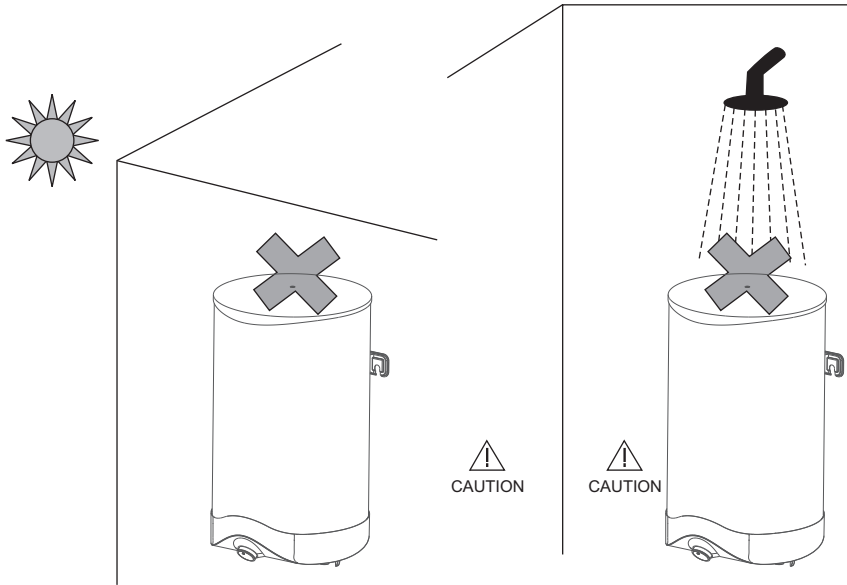

Picture 2

Water Connections

CAUTION

- A. Do not connect the inlet directly to water lifting pump.
- B. Do Not SWITCH ON water Heater without water filled in tank.
1. In case inlet water pressure is more than 0.8 MPa or water pressure head 80 metre, install the dead weight valve before inlet as shown in Picture 2 (not provided with this unit).
2. Minimum height between the water heater and water supply tank should be at least 1 metre.
3. For connecting the inlet & outlet between water heater and bathroom fittings, use metal flexible pipe having plastic nut / plastic adapter.
4. Cold water inlet is marked blue and hot water outlet is marked with red.
5. First, fix the multifunction valve (MFV) to inlet of water heater.
6. Connect cold water inlet to other end of MFV with metal flexible pipe having plastic nut / plastic adapter.
7. Open inlet water tap and allow the water to fill in the water heater. Make sure that the water starts flowing from outlet of water heater.
8. Connect the outlet with metal flexible pipe having plastic nut / plastic adapter, to hot water outlet point of bath fitting. Open the tap & valve and check the water is flowing through the hot water tap.
9. Connect MFV with PVC pipe for drain see Picture 3.

⚠ CAUTION

Ensure no leakage of water through inlet and outlet joints.

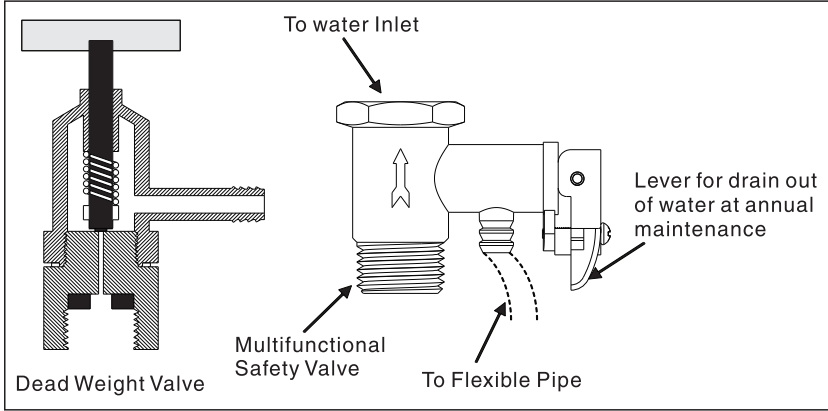

Picture 2

Picture 3

Electrical Connections

1. This unit is provided with all internal connections/wiring made in the factory itself.
2. Make sure that the electrical contact of 3-pins plug and switch is secure with proper earthing.
3. To energize water heater, plug in the 3-pin in socket for electric supply.
4. C 16 A Double Pole MCB or 16 A fuse must be used as a back up protection for overload.

Internal Wiring Diagram -

The schematic diagram shows the internal wiring.

Make sure that the Water Heater is switched off and plugged-off from electrical supply before opening the Inspection cover. Follow the Internal wiring connections as shown in the diagram while carrying out the maintenance.

INTERNAL WIRING DIAGRAM

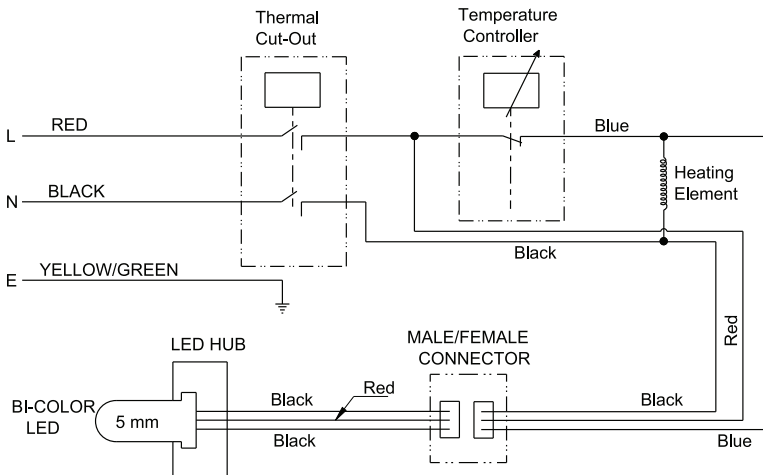

Operation of Water Heater:

A. Using the heater for the first time :

1. Do not switch "ON" before filling the heater with water.
2. Leave the hot water tap open. Now fill the heater by opening the control valve at the inlet.
3. When the heater is full, water will start flowing through the hot water tap. Close the hot water tap.
4. Now the heater will always have water inside. Water drawn will be replaced by water from the over head tank.
5. Always keep the inlet control valve open.
6. Now switch "ON" the power supply to the heater.

B. Using the heater regularly :

1. Always keep the inlet valve open so that water drawn from the hot water tap is automatically replaced from the mains.
2. When the water reaches the required temperature the thermostat will cut-off the power supply automatically.
3. The thermostat setting can be changed by the user to suit outlet water temperature. (DO NOT TAMPER THE SETTING FREQUENTLY)
4. Lowering the setting of the thermostat will give a lower hot water temperature; increasing the setting will give a higher hot water temperature.
5. Initially it may take a long time for the water to get hot, it is recommended to switch "ON" the water heater at least an hour before you want to use it.
6. If you require hot water early in the morning, switch "ON" previous night itself, thermostat would cut-off the power automatically, when the water reaches the set temperature.
7. The heater can also be kept "ON" always, if required since the heater is completely insulated, the water will remain hot. The thermostat will cut-in and cut-off automatically to keep the water at constant temperature. In this way you can always get hot water.

LED Color	Indication
Blue	Water is heating to set temperature
Red	Water at desired temperature is ready

Maintenance & Cleaning:

1. To benefit from the highest standards of service and to ensure your guarantee remains in focus, please always contact HAVELLS approved dealer or HAVELLS Authorised Franchise
2. Always keep the inlet control valve open.
3. Never switch "ON" the water heater without water in the heater. It will damage the heating element.
4. Check condition of metal flexible pipe at-least once in a year. If found damaged replace with new pipes.
5. Check the condition of power supply cord for "No Damages". Replace it by an authentic supply cord in case of damage
6. To increase the life of heating element, de-scaling should be done periodically with the assistance of the nearest authorized service center.

If the water heater is not going to be used for a long time,

- a. Plug Off the power supply,
 - b. Stop Inlet water supply
 - c. Unscrew the drain lever, lift the lever upward to remove the water through drain system provided in MFV.
7. During reuse of water heater
 - a. Ensure Drain Plug lever is reset and screwed
 - b. Open Inlet Valve and fill the water heater till the clean water flows from outlet tap.
 - c. Plug-in the power supply to heat the water
 8. Periodically check the MFV to ensure that it is in operating condition. The MFV should be operated regularly to remove salt deposits and to verify that it is not blocked.
 9. Check proper functioning of the safety valve in every two months by opening and closing the test lever.
 10. The heating element should be checked every year for "No Scale Formation" caused by impurities in the water supply.
 11. We recommend to check anode rod in every year & once it has been used up over 60%, the anode should be replaced with a new one.

For cleaning the element or replacing the anode use the following procedure :

1. Switch off the electric supply to the water heater.
2. Open the hot water taps until the hot water is removed completely.
3. Close cold water supply.
4. Drain the cold water from tank through MFV drain pipe by lifting the drain lever. Remove flexible pipe.
5. Remove the water heater from the hanger hook, after water heater is emptied
6. Remove the inspection cover from bottom , unscrew the heating assembly flange.
7. Clean the container and the heating element assembly to remove scale formation, by using a suitable acid or by gently scraping the scale. Check the heating element surface after cleaning for "No Surface Damage"
8. Replace Heavy Duty anode in case it is worn out .
9. Remount the heating assembly flange. Ensure the Internal wiring connection are made as per the wiring diagram shown in the manual.
10. Hang the water heater on the mounting bracket/ hook provided on the wall. Move the water heater down-ward to ensure that it is seated on bracket properly.
11. Open cold water supply until water flows without interruption from outlet valve.
12. Close the outlet valve and check for "No eventual leakage" around the flange and water connections.
13. When there is no leakage, then switch on electric supply.

DO'S

1. The gate valve at the inlet should always be kept open.
2. To minimize scaling of heating element & the tank, (which takes place rapidly in areas of hard water), drain the water from heater unit periodically. However get this done through a qualified technician / plumber only
3. Always get the water heater serviced once in a year from a Havells authorized service representative
4. Use genuine spares when spares placement is necessary.
5. Switch OFF the power supply to the unit & drain out the water when not in use for a longer period of time. This prevents scaling of the element.
6. In case both the lamps do not glow, do not start the unit by resetting the thermal cutout. Instead contact the nearest customer care centre.

DON'TS

1. Safety devices like safety valve, thermostat, thermal cut-out etc are pre-set from factory & sensitive devices. Do not tamper with them, this could be hazardous.
2. Do not switch ON the heater till it is completely filled with water.
3. In case you observe any abnormality of operation, immediately switch OFF the main power supply to the unit and contact the nearest customer care centre.
4. Never install a pressure reducer valve at the inlet.

WARRANTY*

M/s. Havells India Ltd. ("Company") hereby offers a limited warranty ("Warranty") against manufacturing defect/s for a period of 2 years (two years) on this Water Heater ("Product"), 7 years (seven years) on its inner container and 4 years (four years) on its heating element from the date of invoice on the terms and conditions provided hereinafter.

WARRANTY TERMS AND CONDITIONS

To claim Warranty, it is mandatory that the customer provides the original invoice and wherever possible original Warranty certificate (duly signed and stamped by the selling dealer) must be presented by the customer.

To avail Warranty services, the customer can log in his complaint with the customer care cell.

This Warranty is valid only in respect of the Product purchased in India.

This Warranty is limited to the first purchaser of the Product only.

The Warranty Period specified above shall include the period when the Product is not in use, time taken for repairs, replacements, breakdowns, transit time, etc. No notice of expiry period of Warranty will be given by the Company.

It is clarified that after two years from the date of invoice, Company's responsibility to continue to provide additional Warranty services in terms as agreed upon shall however be limited only to supply of the parts free of cost and any cost(s) incurred towards labour, transportation and any other incidental expenditure for providing the said Warranty services shall be borne by the customer.

The decision to repair or replace any part of the Product shall be at the sole discretion of the Company.

In case of repair or replacement of any part of the Product during the said Warranty Period, the Warranty of the repaired or replaced part shall thereafter continue only for the unexpired period of Warranty.

If the Product is not repairable at the place of installation then the decision of the Company's Authorized Service Representative to take the Product to the service center for repair shall be final. Company's decisions on all questions and complaints regarding the defects, shall be conclusive.

The defective spare parts shall be sole property of the Company or its Authorized Service Partner during the Warranty Period.

In the event of any unforeseen circumstance, and/or spares are not available, Company's prevailing depreciation rules will be binding on the customer to accept as a commercial solution in lieu of repairs.

The depreciation rule will be applicable after one year from the date of purchase.

If repair or replacement of component/part is rendered illegal because of subsequent law changes Company will have no responsibility for procuring replacement of parts if doing so would be commercially impractical.

To avail Warranty services for the Product, any recommendations made by the Company's visiting Authorized Service Representative shall be complied by the customer and if that recommendation requires repair of any electrical installations, wiring or of any third party product attached to the Product, it shall be first undertaken by the customer at his entire cost. Thereafter, the Warranty for the Product can be availed.

Company shall not be held liable or be deemed to be in default for any delay or failure in performance resulting directly or indirectly from causes beyond its control including delay in repairing due to non-availability of any component or accessory, labour problem, restrictions and regulations of the government, public movement, war and any other unavoidable/unforeseen circumstances including any force majeure event, specially vis-à-vis the import of supplies and raw material.

The Warranty provided herein is in lieu of implied conditions and warranties under the law and is confined to the repair or replacement of defective parts and does not cover any economic loss, commercial loss, consequential or resulting liability, damage to the property, or any other harm or loss.

None of the employees and /or Authorized Dealers of the Company have any authority whatsoever to vary the Terms and Conditions of this Warranty.

In the event that any Terms and Condition of this Warranty becomes invalid and/or unenforceable, the remaining Terms and Conditions shall continue in full force and effect.

WARRANTY EXCLUDES OR DOES NOT APPLY:

If the Product or any of its parts/accessories are not properly installed, used, maintained or operated as per the user manual or Product specifications.

If the Product is serviced or repaired by any person other than the Authorized Service Representative of the Company.

If customer violates Warranty Terms and Conditions, instruction manual guidelines, recommendations of Authorised Service Representative and/or operates the Product otherwise than as per Product specifications.

If the serial number affixed by the Company on the Product or any part thereof is damaged, defaced, obliterated or erased/ tampered with for any reason whatsoever or if Product is refurbished/modified.

If the Product is operated in conditions otherwise than normal conditions (e.g., abnormal voltage surge, extreme heat, corrosive/alkaline/acidic atmosphere, dust, damage from sea water, pollution, chemical environment, extreme environmental conditions, sulfur in the air, installation near the open drainage system etc.).

If the Product is installed in direct sunlight, rain, water splashes etc.

If safety valves and anodes are not kept under right working conditions.

If multi-functional safety valve is not used or installed with the Product.

If the Product is used for any commercial purpose.

Any harm caused due to accident, negligence, improper maintenance, mishandling, tampering, incurred in transit by the customer or which can be attributed to the fault of the customer.

Any harm resulting from any unforeseeable circumstances such as force majeure event etc.

Any harm caused due to any defect in any electrical/civil installation(s), wiring or third party products.

Any liability resulting from any un-authorized adaptations, attachments and/or adjustments to the Product or from a third party apparatus or equipment.

Any damage caused due to quality of water, scaling or sediment deposits in the water tank.

Any damage to the Product due to household pets, rodent or any other insect/animals.

Corrosion, rusting, plastic parts, accessories and normal wear and tear of the Product.

Customer Name : Model No. :

Serial No. :

Invoice No. :

Date of Purchase :

Dealer`s Name, Address :

Dealer`s Seal & Signature

Actual products may vary in colour, design, description and colour combination etc.

Although every effort has been made to ensure accuracy in the compilation of the technical detail within this publication. Specifications & performance data are constantly changing.

Copyright Subsists. Imitation of trade dress, graphics and color scheme of this document is a punishable offence.

Figure and Drawings are for illustrative purpose only.



HAVELLS

190124V2

Havells India Ltd.

QRG Towers, 2D, Sector -126, Expressway, Noida - 201304 (U.P.) India

E-mail: customercare@havells.com, Website: www.havells.com

Customer Care No. 08045 77 1313

Join us on Facebook at www.facebook.com/havells and share your ways to save the planet!

CIN - L31900DL1983PLC016304